

We sell quite a few of the EZServo chips for a couple of reasons. They are very cheap and they are rock solid and easy to use. We have been asked many times if we have a circuit board that this chip can be used with. The answer is YES.

The Athena Work Board Basic or Deluxe work like a charm. Use the Athena WorkBoard Deluxe if you want to breadboard and experiment with various configurations. Use the Athena WorkBoard Basic if you want to wire a permanent solution.

To set the board up you need to set the jumpers as follows.



DCE (Default) = PC

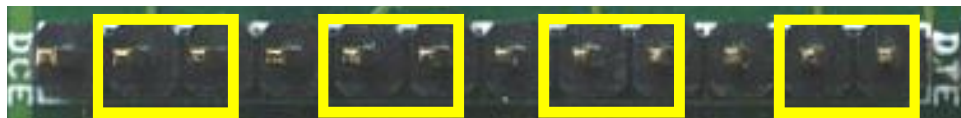

DTE = Pocket PC

To connect the EZServo to a PC use the DCE jumpers. To connect to a Pocket PC use the DTE jumpers. Note that you will also need a gender changer for pocket PC connection. If you have a null modem you can use the DC configuration for the Pocket PC.



ATN is not connected to DTR

Remove the AEN jumper as shown. This allows the baud to default to 9600 on the chip. In order to use the board at 19200 you need to pull the AEN lead low by placing a jumper from ATN to Gnd.



Set the Chip type to Athena as shown.

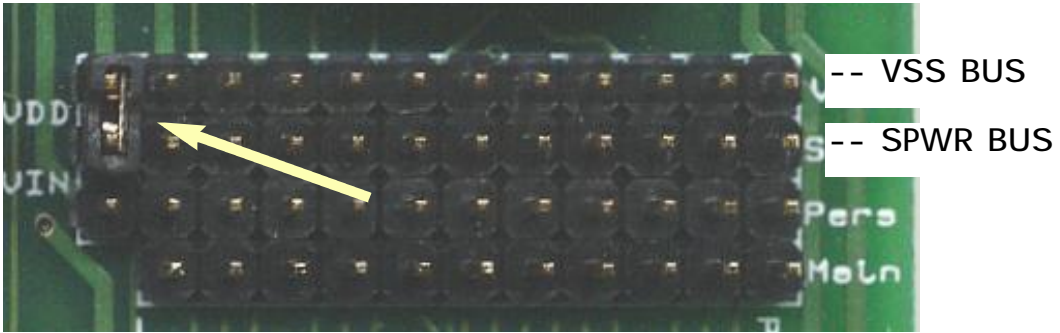

Set the Servo Power jumper. You can use the built in regulator for 1 or 2 servos but if you need to control more than 2 servos at a time you need to set the jumper to VIN.

When using Vin do not supply more voltage to the board than the servos can handle you will burn them up. Normally this is 7.2 Volts.

You can use the buss header to connect the servos but you will need to jumper the following wires on the WorkBoard.

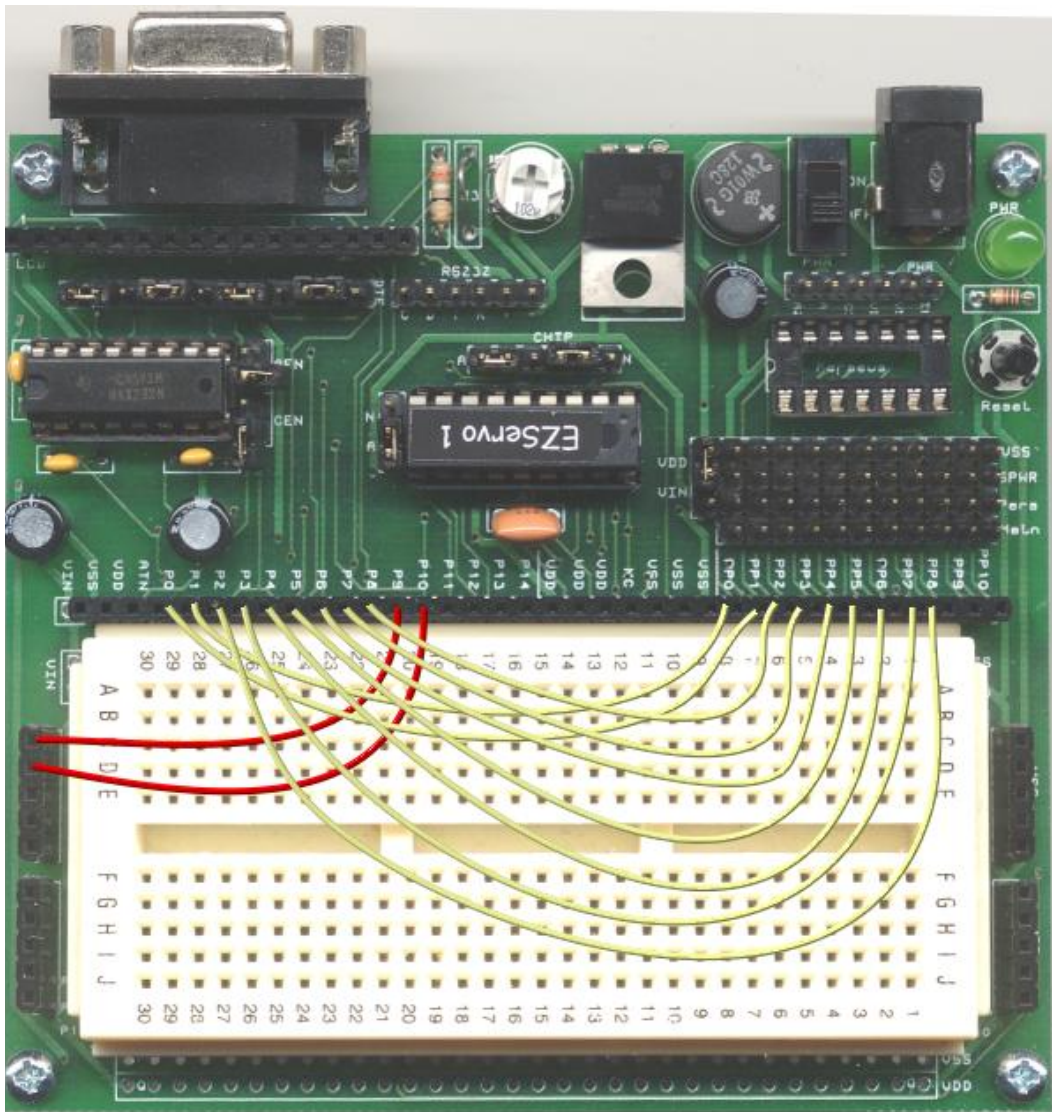

Jumper

- P0 - PP1
- P1 - PP0
- P8 - PP2
- P7 - PP3
- P6 - PP4
- P5 - PP5
- P4 - PP6
- P3 - PP7
- P2 - PP8

- P9 - Vss
- P10 - Vss

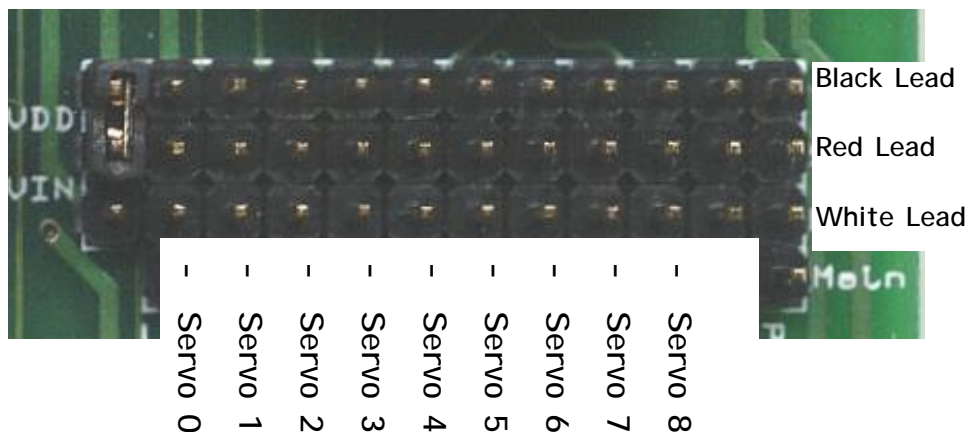

If you want to use VEX Servos you can not use the standard header located on the Workboard. The Vex servos have a male connector so you have to use the Deluxe breadboard or build the board with female headers instead of the male ones. Note that you can also attach female headers to the Basic WorkBoard prototype area.

Here is how we do it with a bread board.

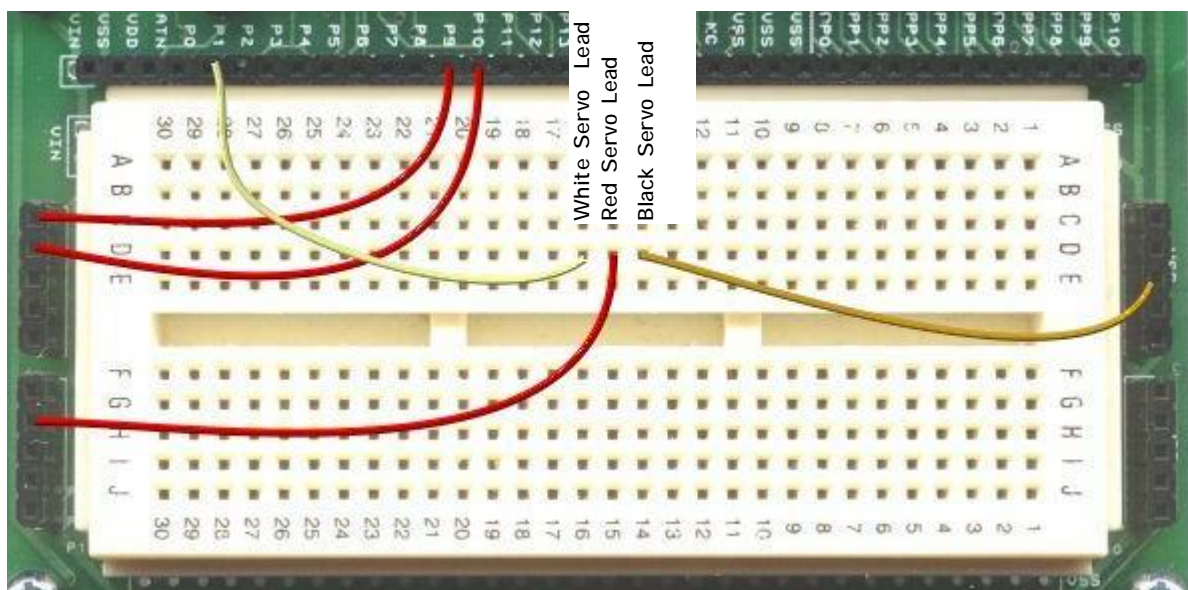

- | | |
|--------------|---------------|
| Servo 0 = P1 | Mode = P12 |
| Servo 1 = P0 | Sync = P14 |
| Servo 2 = P8 | Select0 = P9 |
| Servo 3 = P7 | Select1 = P10 |
| Servo 4 = P6 | |
| Servo 5 = P5 | |
| Servo 6 = P4 | |
| Servo 7 = P3 | |
| Servo 8 = P2 | |

Please check the EZServo1 datasheet for a description of the command structure. You can also use Zeus on a laptop or PC.

Zeus has a EZServo1 library that makes talking to the EZServo1 chip very easy.

Zeus Program

```
'EZServo1 Test Program
func main()
    dim x
    InitEZServo1(1,1)

again:
    for x = 600 to 2200 step 10
        EZServoValue(0,x)
        pause(1)
    next

    for x = 2200 to 600 step -10
        EZServoValue(0,x)
        pause(1)
    next

    goto again
endfunc

include "+Lib\EZServo1.Lib"
```

The InitEZServo commands sets the comport used in the program. If you want to use comport 2 use the command **InitEZServo1(1,2)**

Note that the first parameter is the com channel that Zeus uses.

ServoValue(Servo,Value) Sets the the particular servo. The value is a 16bit value and 1000 to 2000 are typacle but some servos such as the Vex use a range of 500-2400.

ServoState(Servo,State) Turns the servo on or off. A state of 0 turns off the servo and a state of 1 turns it back on.

Note that you can connect more than 1 board to the PC but you will have to remove the EZ232 chip from the board and tie the following leads on the main connector together. Port 11, Port 12, Atn, Vss and Vdd.

You will need to change the select settings on the EZServo chip by setting ports 9 and 10. You can still use the Zeus software. Just use the Servo numbers as follows:

Select 0	Select 1	Ports
Low	Low	Servos 0-9
High	Low	Servos 20-29
Low	High	Servos 30-39
High	High	Servos 40-49

EZServo1	http://kronosrobotics.com/xcart/customer/product.php?productid=16273
Athena WorkBoard PCB	http://kronosrobotics.com/xcart/customer/product.php?productid=16460
Athena WorkBoard Deluxe	http://kronosrobotics.com/xcart/customer/product.php?productid=16457
Athena WorkBoard Basic	http://kronosrobotics.com/xcart/customer/product.php?productid=16473
ZeusPro	http://kronosrobotics.com/xcart/customer/product.php?productid=16479